

Model Walkthrough Technical Note

CDISC DDF Team, 29th March 2022, third draft

Changes

- 28th March 2022 – First draft
- 29th March 2022 – Second draft after an initial review
- 29th March 2022 – Third draft after further comments received

Purpose

This note provides an overview and walkthrough of the CDISC and TransCelerate Digital Data Flow (DDF) Unified Study Definitions Model (USDM). The aim is to guide the non-technical reader when reviewing the model.

Note: this is an early draft of this note and it will be updated as comments are received, and review of the model takes place.

Method

The walkthrough references the Entity Relationship Diagram and the associated DDF Controlled Terminology and take each class in turn and note various aspects of the model. The USDM UML model should be referenced as the normative artefact. It is strongly recommended that the Controlled Terminology and the Entity Relationship Diagram (ERD) be examined together to understand the model.

The model walkthrough has been divided into several logical areas to aid understanding. These areas reflect the section organization within the model.

The figures within the document provide a high-level view of the relationships between the classes. The figures are for information only. The UML is the normative source, and the ERD provides an easier way to consume the information.

The diagrams within this document have been designed to provide the simplest view of the model possible with a minimum of clutter to allow non-technical reviewers to relate the model to the subject domain.

Note the many to many tables that are present in the ERD have been omitted for clarity. Also, all relationships are noted as one to many or many to many. No attempt has been made to identify the precise cardinality where the model allows for zero instances etc. The purpose of this document is to provide an overview of the model, the UML provides the normative definition.

Study & Protocol

The classes in this area link a study to its associated protocol, its type and phase plus its identifiers.

A study can be related to a single protocol which may have many amendments. A study is of one study type and is of one Study/Trial Phase, e.g., Phase I, Phase I/II, Phase II, etc, but can have many identifiers, for example a sponsor identifier and an identifier issued by a trial registry.

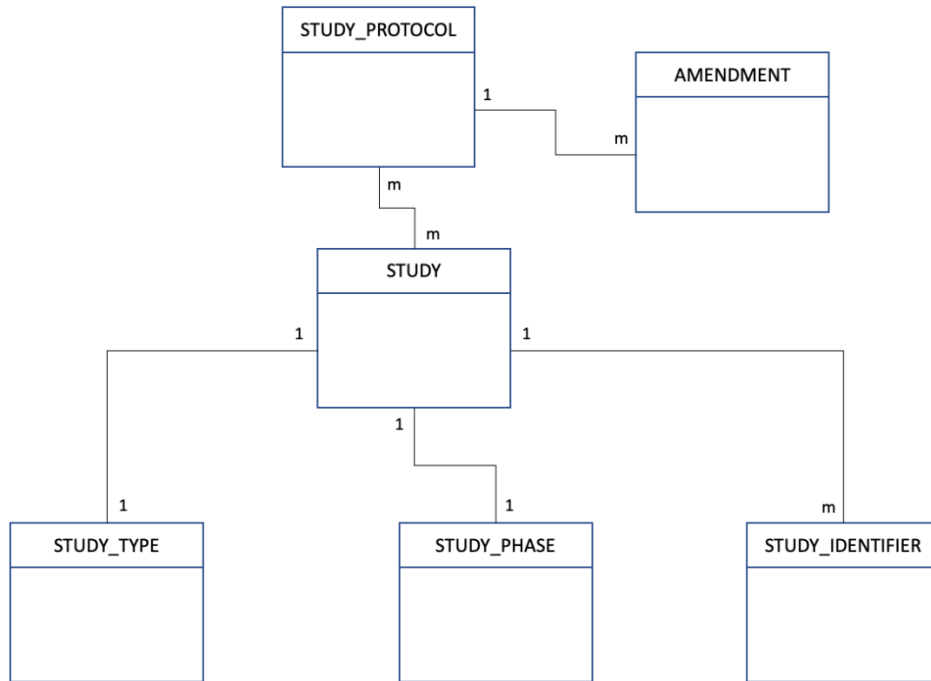

Section History

The section history is a collection, or list, of section objects of a specific type, be it populations, interventions, study designs, etc. The section history can be accessed via both the study and study design classes.

The section history allows access the entire change history of any particular section at either the study level or the study design level. The section history connects the study to the study design.

Study Design Section

The study design class binds the design as a whole and links to the constituent parts. It does contain the trial intent and the trial type.

The study design class links to the study class allowing for multiple designs for a single study.

Investigational Interventions Section

This section allows for the specification of the interventions, the treatment under investigation, used by a study design providing a description and a model for each. The investigational interventions class can also be linked to one or more external code list entries via use of the code class.

The study design class is linked to the investigational interventions class via the section mechanism.

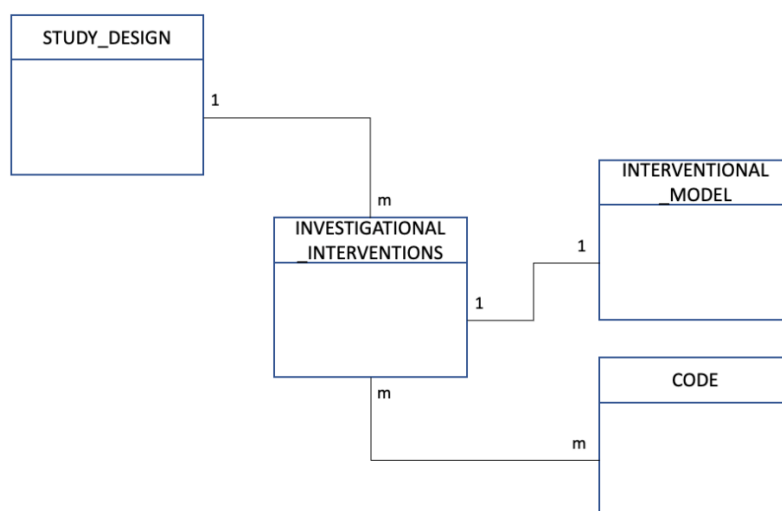

Study Indication Section

This section allows for the study indications – the disease or medical condition intended to be targeted by the treatment – to be defined and, again, linked to external coded entries using the code class.

The study design class is linked to the indication class via the section mechanism.

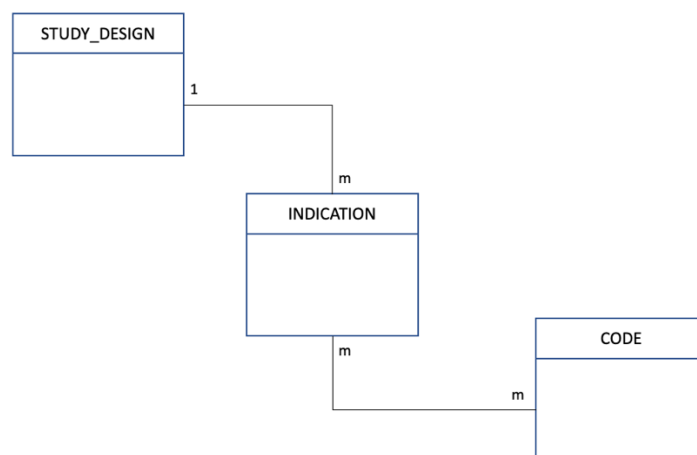

Population Section

Study populations are defined within this section. The study design is linked to the populations via the section mechanism with the population being related to a single estimand. An estimand can have many intercurrent events that can be coded.

The study design class is linked to the population class via the section mechanism.

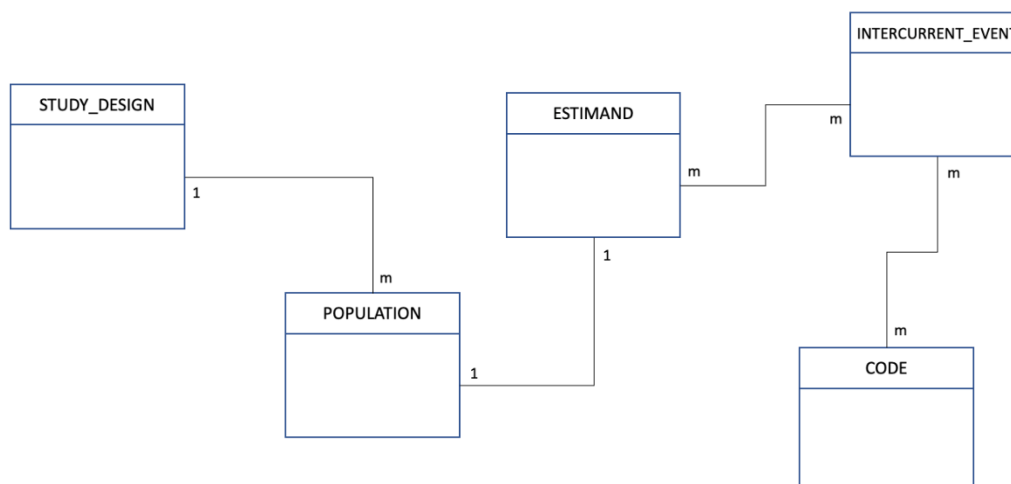

Note: Late in the work prior to public review it was noted that the model did not make clear the notion of “Study Population” or “Study Target Population” and “Analysis Population”. To ensure this comment was not lost a new JIRA ticket was created, DDF-231. This ticket will be processed as part of the public review.

Objectives Section

This section allows for study objectives to be defined.

A study design may have many objectives with an associated level. Each objective can be related to many endpoints (which may be part of many objectives) with each endpoint have a single purpose and level.

The study design class is linked to the objective class via the section mechanism.

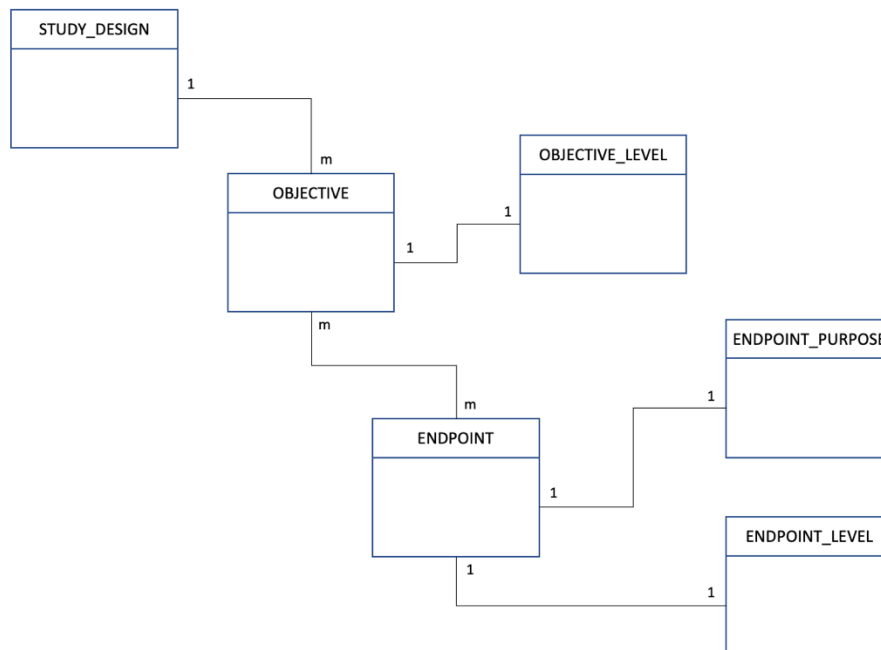

Workflow Section

The workflow section allows for multiple workflows to be constructed within a study with the associated timing information.

The study design can be linked to multiple workflows each of which has multiple items within it. The workflow and the workflow items have associated timing information, both start and end points in time. The workflow items link to one encounter (visit) and activity.

The study design class is linked to the workflow class via the section mechanism.

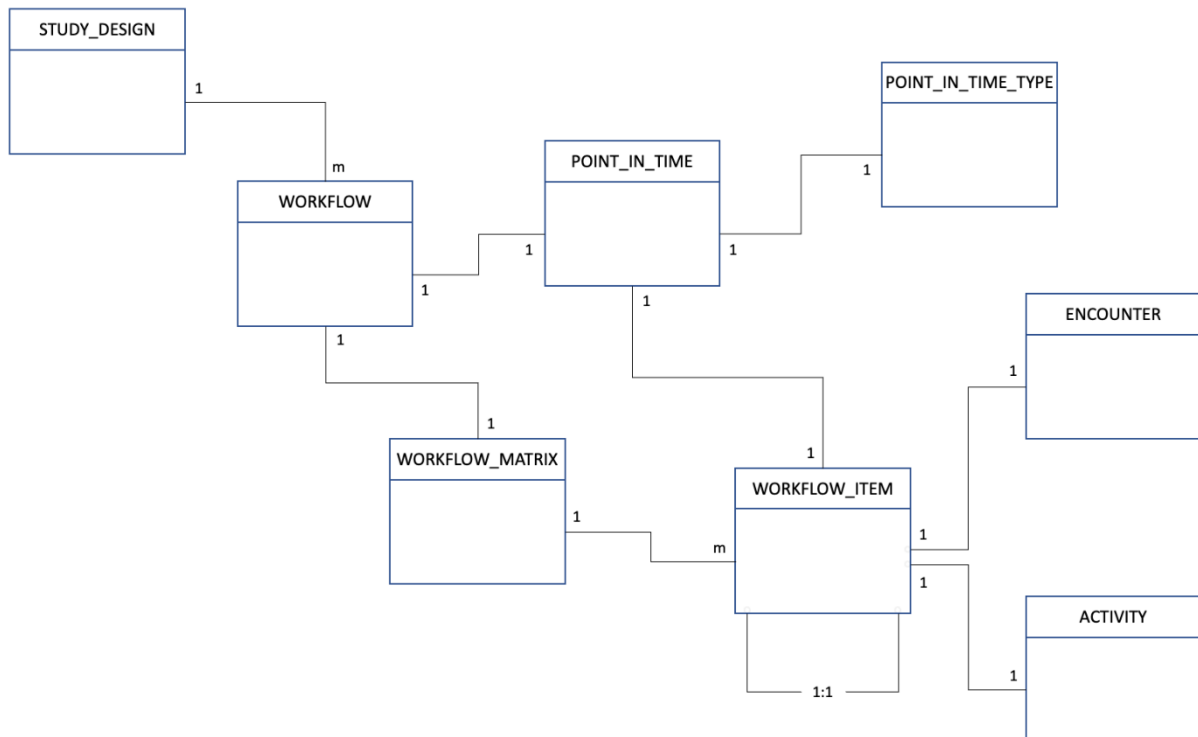

Study Cell Section

The study cell section provides the model logic for arms, epochs, cells, and the associated detailed study logic.

The intersection of a study arm and a study epoch defines a study cell that links to study elements. Study epochs are linked to encounters (visits) and a workflow item joins an encounter to an activity. Encounters and study elements both are associated with rules.

The study design class is linked to the study cell class via the section mechanism.

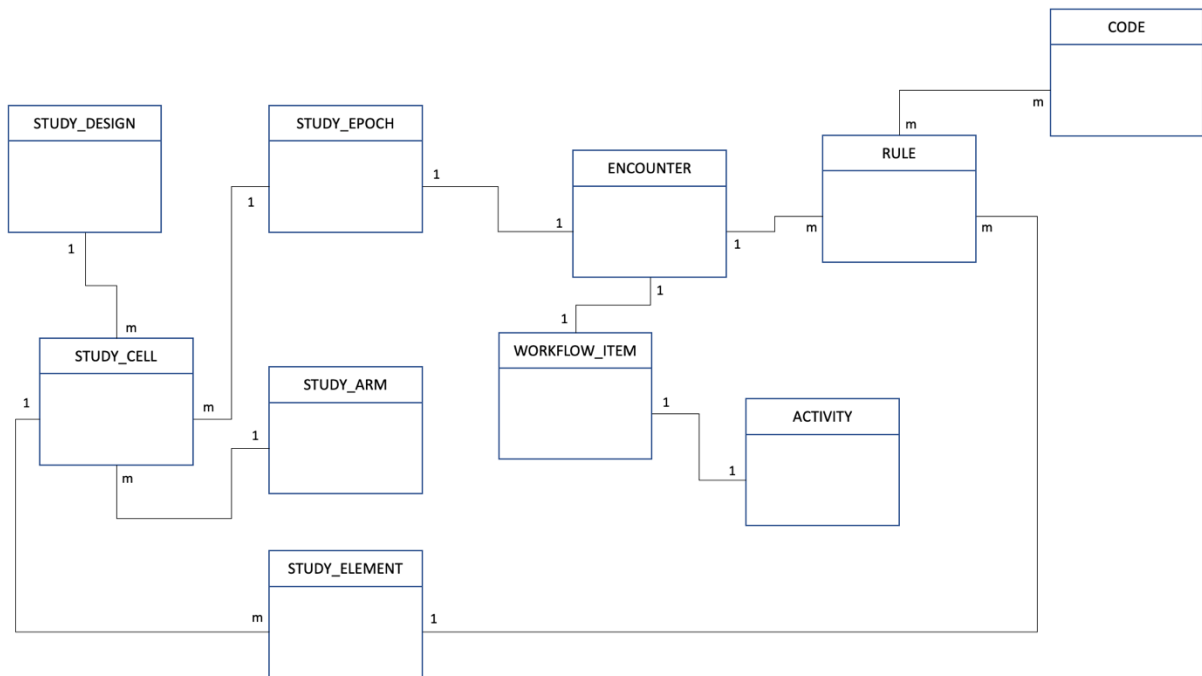

An encounter is further defined by its type, the contact mode, and the setting for the encounter. A study arm has a type and origin details. A study epoch just has a type.

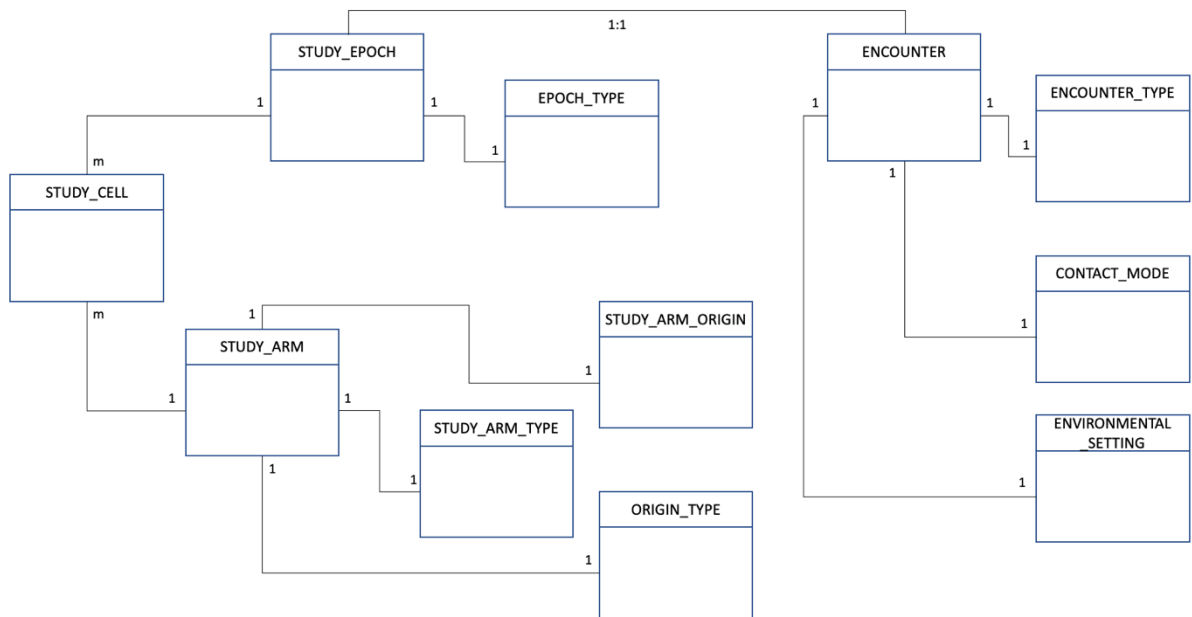

An activity can be linked to many study data and procedures with a procedure having an associated type.

